

Electro-Pneumatic Positioner ALP-1000 Series Instruction Manual



Electro-Pneumatic Positioner ALP-1000

Contents

1. General	p1
2. Features	p1
3. Specifications	p1
4. Ordering Symbols	p2
5. Structure	p2
6. Principle of operation	p2
7. Block Diagram	p3
8. Installation	
8-1. Example of attaching to actuator	p3
8-2. Connection with feedback shaft	p3
8-3. Cam attaching procedure	p4
8-4. Attaching procedure of opening degree indication plate	p4
9. Air piping connection	p5
10. Electrical wiring	p5
11. Adjustment	
11-1. Zero adjustment	p6
11-2. Span adjustment	p6
11-3. Auto/Manual switch	p6
11-4. Seat adjuster	p7
12. Maintenance and check	p7
13. Caution and handling	p8
14. Trouble shooting	p8
15. Option	p9
15-1. Pilot valve with output orifice	
15-2. Feedback lever type	
16. Dimensions	p10
17. Introduction of positioner with PT	p11

Electro-Pneumatic Positioner ALP-1000

1. GENERAL

The electro-pneumatic positioner ALP -1000 is used for rotary operation of pneumatic rotary valve actuators by means of electrical controller or control systems with an analog output signal of 4 to 20 mA or split ranges.

2. FEATURES

1. There is no resonance in the range of 5~200Hz.
2. Performing ½ Split Control without any other substitutes.
3. Easy to adjust zero and span.
4. Easy to convert from Reverse Action to Direct Action or vice versa.
5. Easy Feedback Connection.
6. Fast and accurate response.
7. Low air consumption.
8. Easy to protect from hunting effect by using output orifice in small size of actuator.
9. Designed as block build structure for maintenance and repair.

3. SPECIFICATIONS

Item Type	Single Acting	Double Acting
Input Signal	4 ~ 20mA DC	
Impedance	250 ± 15 Ω	
Supply Pressure	0.14 ~ 0.7 Mpa	
Stroke	0 ~ 90°	
Air connection	PT (NPT) 1/4	
Gauge Connection	PT (NPT) 1/8	
Conduit	PF 1/2	
Explosion Proof	ExiallBT6, ExdmllBT6, ExdmllCT6	
Degree of Protection	IP66	
Ambient Temperature	-20℃ ~ 70 ℃ (-4°F ~ 158 °F)	
Linearity	±2% F.S.	
Hysteresis	1% F.S.	
Sensitivity	±0.5% F.S.	
Repeatability	±0.5% F.S.	
Air Consumption	5 LPM (Sup. = 0.14 Mpa)	
Flow Capacity	80 LPM (Sup. = 0.14 Mpa)	
Material	Aluminum Diecasting	
Weight	Approx 2.8kg with junction box	

Electro-Pneumatic Positioner ALP-1000

4. ORDERING SYMBOLS

Model	Output Type	Acting Type	Option	Explosion Proof	Lever Type	Orifice Type	Connection Type
ALP-1000	■ Rotary	S Single Acting	Standard	m ExdmIIBT6	1 M6 x 40L	1 Below 90cm ³	1 PT
	■ Linear	D Double Acting	T +PT (Internal)	i ExiaIIBT6	2 M6 x 63L	2 90 ~ 180cm ³	2 NPT
			B +LBS	n Non-Explosion	3 M8 x 40L	3 Over 180cm ³	
					4 M8 x 63L		
					5 NAMUR		

<NOTE>

1. Based on temperature 20°C, absolute pressure 760mmHG and relative humidity 65%.
2. Explosion Proof (ExdmIIBT6), IP66 as standard.
3. Double Acting as standard.
4. In standard ½ split range is available by adjusting the Span.
5. Contact us except standard.

5. STRUCTURE

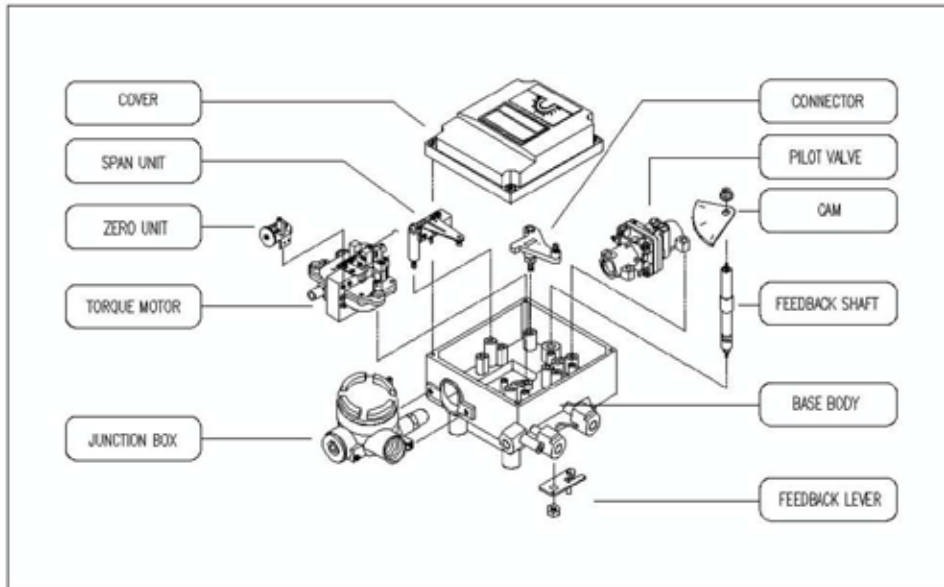

6. PRINCIPLE OF OPERATION

Increase the input current signal to change in lift position of valve. Force exerted by ①Torque Motor reduces Nozzle Back Pressure with increase in gap between ②Flapper and ③Nozzle. Then ④Spool moves upward and the ⑤Seat opens simultaneously. Air pressure of OUT1 pipe is discharged to ⑩Actuator. As pressure in the actuator chamber goes up, ⑥Actuator stem start to rotate. The movement of ⑦Actuator stem exerted force to the ⑧Feedback Spring through Feedback Shaft connections. Then ⑩Actuator will stop at the point of force balance exerted by the input current signal and the feedback spring.

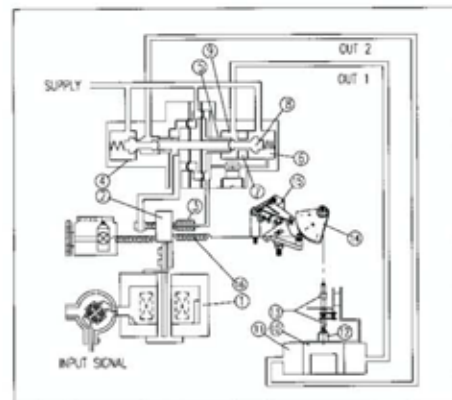

Electro-Pneumatic Positioner ALP-1000

7. BLOCK DIAGRAM OF ALP-1000

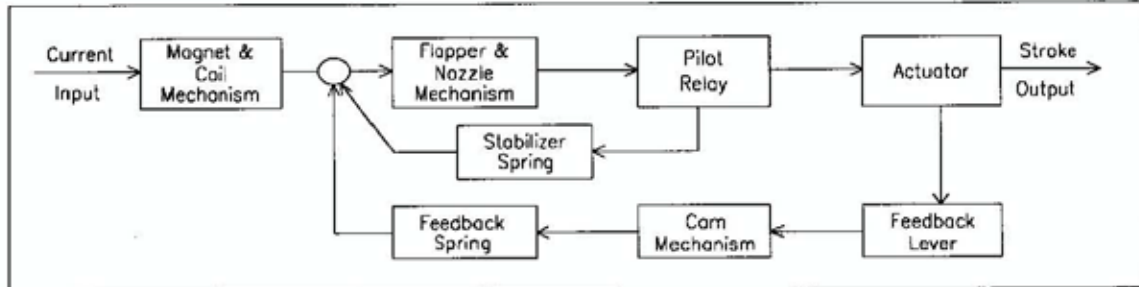

8. INSTALLATION

8-1. Example of attaching to actuator

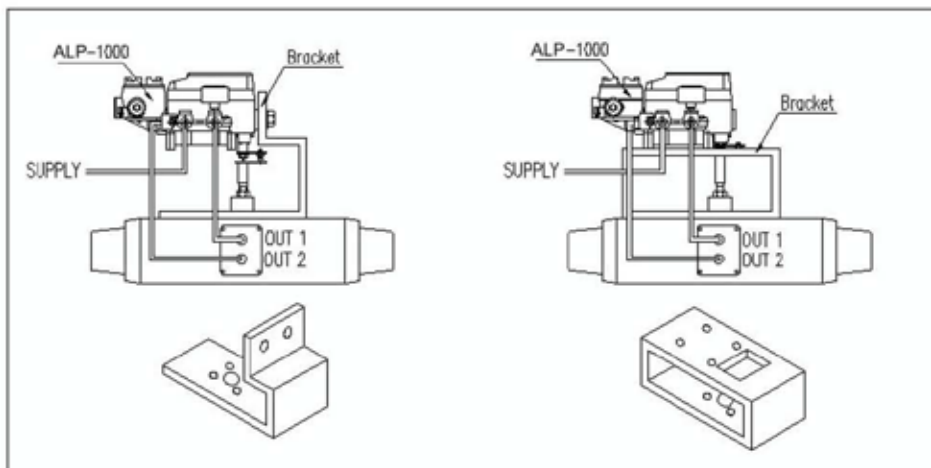

8-2. Connection with feedback shaft

Attach to the position at which the positioner feedback shaft and the rotary actuator main shaft are almost concentric (range in which the spring pin of feedback shaft edge enters the hole of fork lever assembly shaft edge).

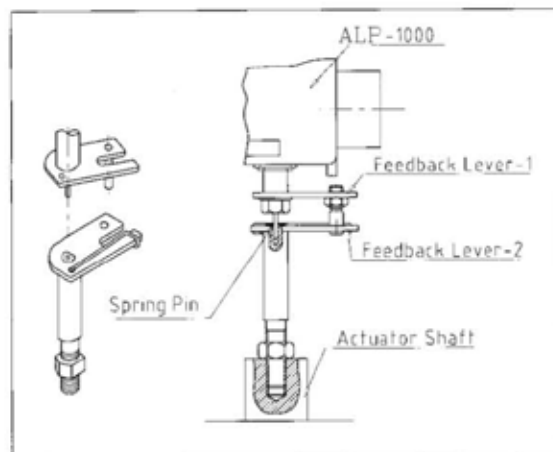

Electro-Pneumatic Positioner ALP-1000

8-3. Cam attaching procedure

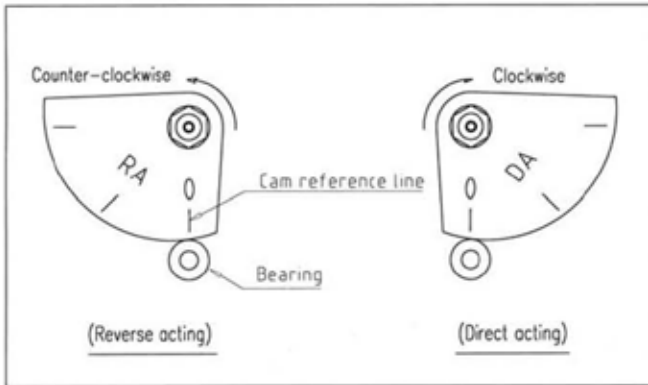

- (1) Use the DA face of cam to turn the actuator main shaft clockwise (viewed from the positioner front cover side) at the time of input feedback shaft. Use the RA face to turn it counter-clockwise (reverse action). Correctly attach the cam to the flange part of feedback shaft.

- (2) Attach the cam in the procedure of loosening the hexagonal nut with flange first, setting the using actuator to the starting position and then setting the cam reference line and the bearing contact point of span adjusting arm unit to the matching position.
- (3) Do not apply the supply pressure when attaching the cam as otherwise it is very dangerous.
- (4) When the positioner is shipped out of our plant, the cam is tentatively tightened to the shaft. Be sure to firmly lock the cam to the lock nut. (tightening torque 2.0 ~ 2.5 Nm (20 ~ 25 kgfcm).

8-4. Attaching procedure of opening degree indication plate

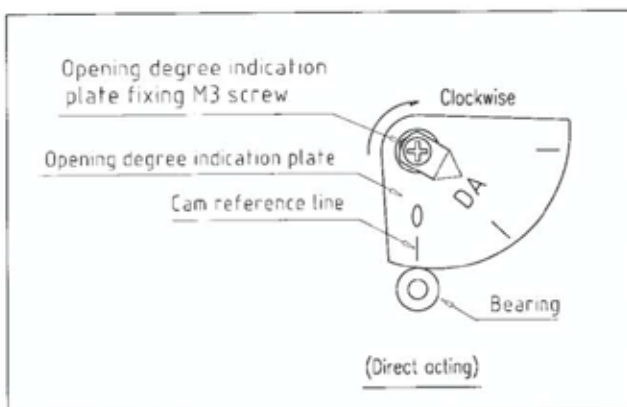

Lock the cam and then adjust the zero point and span. Then fix the opening degree indication plate to the shaft using the M3 screw provided. At the time, set the opening degree indication plate to the state of attaching reference line.

Electro-Pneumatic Positioner ALP-1000

9. AIR PIPING CONNECTION

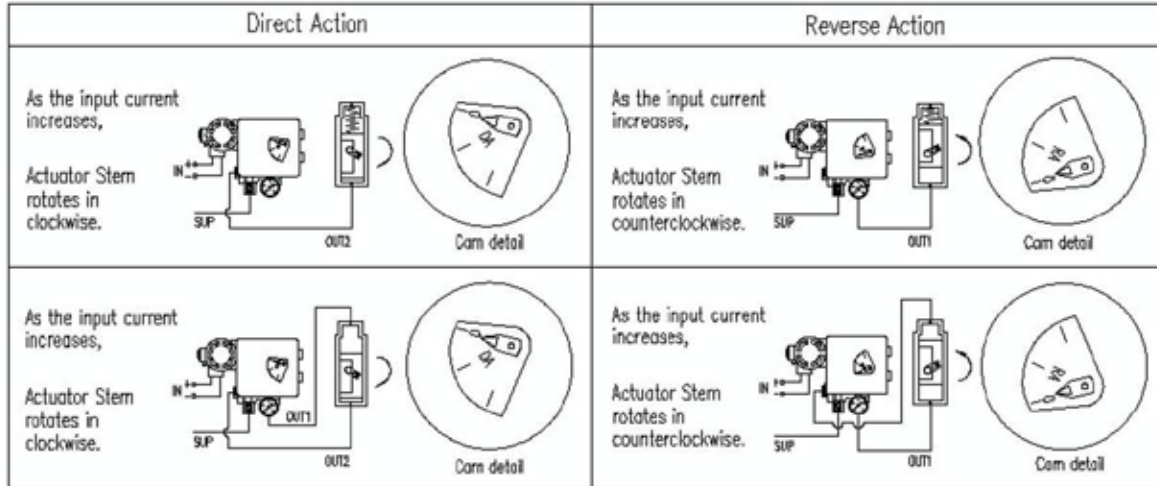

- ① Fully purge the pipe to remove foreign matter.
- ② Use a clean supply air fully removed humidity and dust.
- ③ Use ALP-200 filter regulator to keep supply air pressure constantly
- ④ When using the double acting type as the single acting type, blind either OUT1 or OUT2 and also remove the pressure gauge to close its connection.

10. ELECTRICAL WIRING

Connect the (+) and (-) output terminals from the regulator with the (+) and (-) input terminals, respectively, of the positioner Junction box
 For Explosion Proof, both pressure tight conduit thread connection type and pressure tight packing type are available.

Use Cable Gland in pressure tight packing type. (Cable O.D.= 9.0~ 11).

Use PF ½ standard for conduit thread connection type.

Close Junction box cover and lock Key lock screw.

There is a Spare Bolt in terminal board.

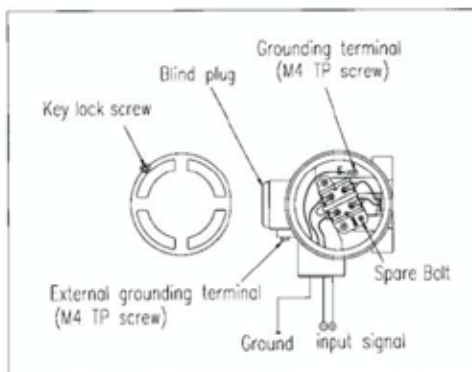

ExdmIIBT6

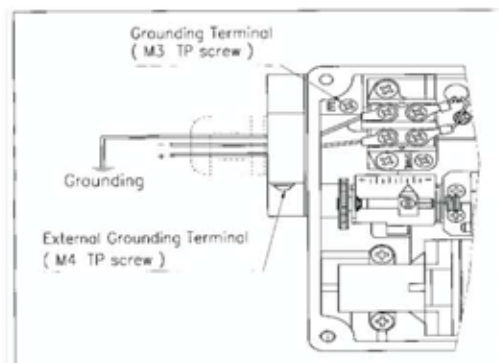

ExialIBT6

Electro-Pneumatic Positioner ALP-1000

11. ADJUSTMENT

Check the following prior to starting the adjustment.

Check that the pipeline is correctly connected with the pressure supply port and OUT1 and OUT2 port.

Check that the wires are correctly connected with the (+), (-) and grounding terminals.

Check that the actuator and positioner are sturdily connected.

Check for locking of the auto/manual changeover screw of pilot valve (fully tightened in the clockwise direction).

Check that the span adjusting lever of internal feedback lever is attached to the correct (Direct or Reverse) position.

Check for correct use of the cam face (Direct or Reverse) and that flange nut is firmly locked.

11-1. Zero Adjustment

Set an signal to the Stroke starting signal(4mA) then turn the Zero Adjuster clockwise or counterclockwise.

In case of Spring Actuator, check if it is set to standard pressure in Zero Point. If not, repeat Zero adjustment.

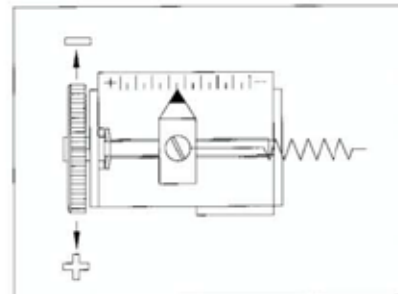

11-2. Span Adjustment

Adjust Range Adjustment so that an Actuator stops at 0% position of the Stroke by the 0% applied input signal and 100% position for 100% input signal respectively.

Check Zero Point and repeat Zero Span Adjustment.

1/2 Split Range can be used by Zero and Span Adjustment.

After Setting, tighten up Lock Screw of Span adjustment.

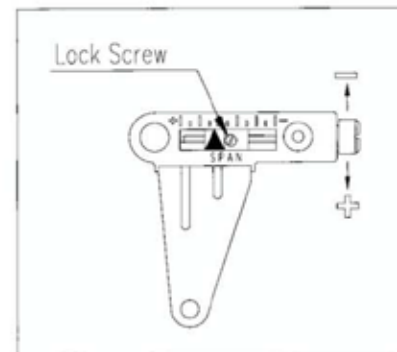

11-3. Auto / Manual Switch

This is a Switch for changing Auto and Manual.

Shipped products is set for Auto. To use Manual operation, turns A/M Switch counterclockwise.

In manual operation, the pressure of ALP-200 regulator connects to Actuator.

After using, return switch to "A".

Not available for Single Acting-OUT2 and Double Acting.

Electro-Pneumatic Positioner ALP-1000

11-4. Seat Adjuster

No need to adjust at the field because Seat Adjuster is to be adjusted before shipment for balanced pressure point of output pressure.

Seat Adjuster is always used for Double-acting.

If need to change balanced pressure point of output pressure, use Seat Adjuster.

If the sensitivity is poor because of the actuator type of load condition, turn the seat adjuster screw clockwise. If hunting occurs, turn the seat adjuster screw counter-clockwise.

(The amount of turning varies by actuators. Do not loosen the stopper screw at this time since it is set to avoid coming off the seat adjuster.

If hunting occurs due to an actuator of small capacity, refer to description in chapter 15. OPTION.

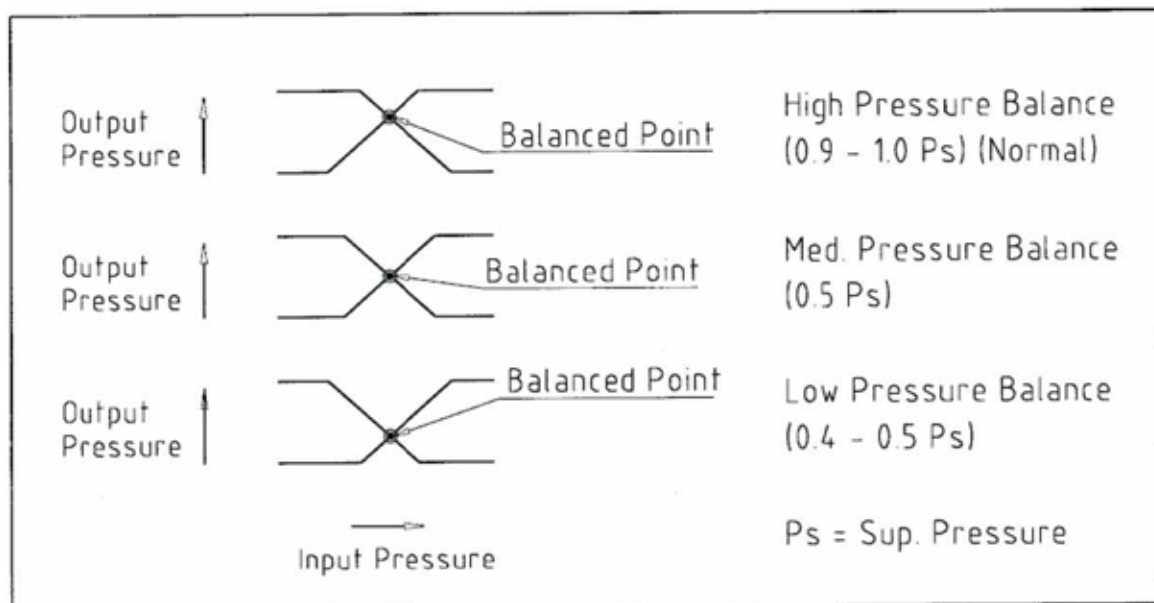
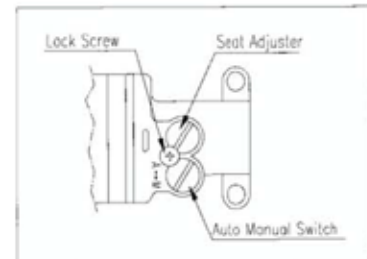

12. MAINTENANCE AND CHECK

If the supply air is fouled, the positioner may not operate normally.

Periodically check the compressed air cleaning system and make sure that clean air is always supplied.

When you disassemble the pilot valve, coat grease to the O-ring of the sliding section.

When the fixed orifice is clogged with carbon particles or others, remove the pilot valve Auto/Manual changeover screw (built-in fixed aperture) and clean it by inserting a 0.2 wire into the aperture. If it must be replaced with new one, stop the supply pressure and remove the stopper screw of the pilot valve.

Check the positioner once a year. When you find excessively worn diaphragm,

O-ring and other packing or any unit, it should be changed with new one.

Treatment at an early stage is especially important if the positioner is used in a place of severe environment like coastal area.

Electro-Pneumatic Positioner ALP-1000

13. CAUTION AND HANDLING

Do not apply large vibration or impact to the positioner. It causes trouble.
 The positioner must be handled very carefully during transportation and operation.
 If the positioner is used under temperature outside of the specification, the sealing materials deteriorate quickly and also the positioner may not operate normally.
 Do not remove the terminal cover at a dangerous position during power conduction.
 Be sure that the terminal cover and body cover are put on during the operation.
 If you leave the positioner at the operation site for a long time without using it, put the cover on it so that the rain water does not enter the positioner.
 If the atmosphere is of high temperature or high humidity, take measures to avoid condensation inside. The condensation control measures must be taken thoroughly for export shipment.

14. TROUBLE SHOOTING

Condition	Cause	What to do
Not operated with Input Signal applied	Too low or none supply air	Input supply air
	Loose connection	Tighten set screw of Terminal
	Wrong wiring for (+) and (-)	Connect wiring (+) and (-)
	Short or open circuit of terminal Motor	Replace Motor Unit
	Clogged Nozzle	Replace Motor Unit
	Loose or wrong setting of Feedback Lever	Correct setting and tighten
OUT1 pressure raised And stay, does not Come down	Leakage of A/M switch	Tighten or replace A/M switch
	Wrong contact or search of Flapper	Replace Motor Unit
	Clogged fixed orifice	Clean or replace fixed orifice
Output pressure is operated by A/M Switch only	Clogged nozzle	Clean nozzle or replace Motor Unit
Hunting is occurred	Off-positioned stabilizer spring	Insert stabilizer spring
	Too low of actuator volume	Insert orifice
	Clogged fixed orifice	Clean or replace fixed orifice
Actuator is operated by On/Off only	Wrong connection of OUT1 and OUT2 tube	Correct position of tube
Linearity is not good	Wrong setting of feedback lever	Readjust setting of feedback lever
	Wrong Zero, Span adjustment	Readjustment of Zero, Span Adjustment
	Supply pressure is unstable	Replace regulator
Hysteresis is not good	Wrong setting of Seat Adjuster	Readjust Seat adjuster
	Loose connection of actuator and positioner	Tighten connection
	Cam shaft is worn out	Replace Cam Shaft

Electro-Pneumatic Positioner ALP-1000

15. OPTION

15-1. Pilot valve with output orifice

Hunting may occur when the positioner is attached to a small capacity actuator. In such case, use a pilot valve having a output orifice for OUT1 and OUT2. The output orifice is removable. The output orifice types (Refer to description in chapter 4. Ordering Symbols.)

Volume of actuator	Output orifice diameter	Ordering No.
Below 90cm ³	φ 0.7	①
90 ~ 180 cm ³	φ 1.0	②
Over 180 cm ³	None	③

After pulling out the O-ring from OUT1 and OUT2 port, push proper orifice and then mount the O-ring to OUT1 and OUT2 again. When mounting the output orifice, pay attention not to let dust and others enter the port hole. If the hunting dose not stop even after mounting the output orifice, please Contact us

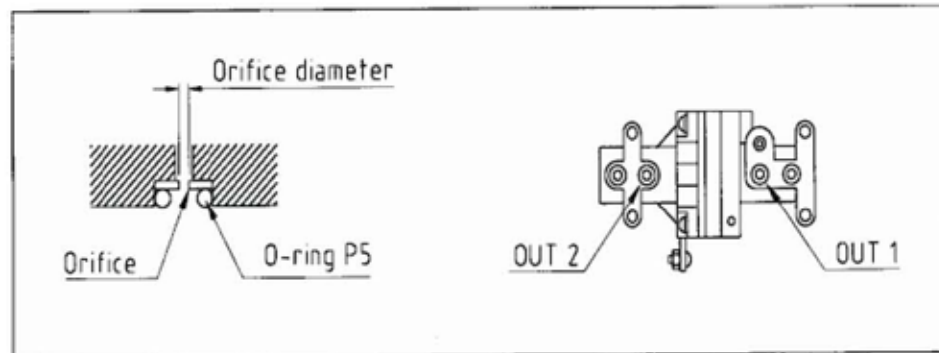

15-2 Feedback lever Type

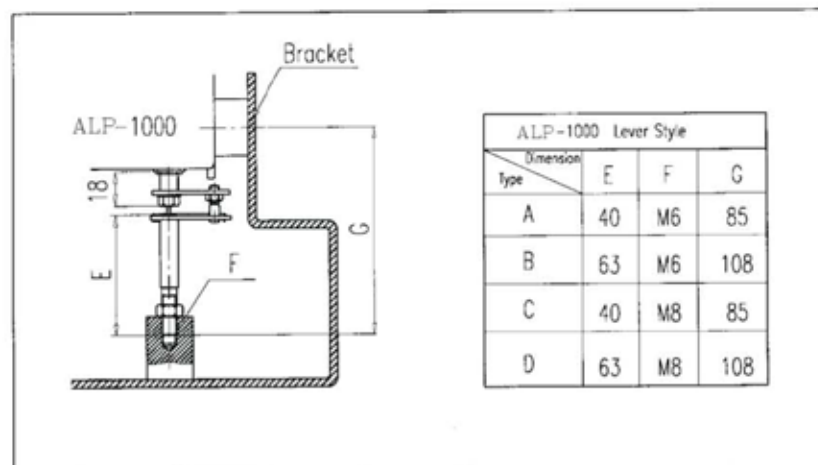

Electro-Pneumatic Positioner ALP-1000

16. DIMENSIONS

